

Grove GMK3060

Product Guide

ASME B30.5
Imperial 85%



Features

- 9,7 m – 43 m (32 ft – 141 ft) six-section full power boom
- Patented TWIN-LOCK™ boom pinning system
- 8,7 m – 15 m (28.5 ft – 49.2 ft) bi-fold lattice swingaway, hydraulic luffing or manual offset
- 13 600 kg (29,983 lb) counterweight with hydraulic removal system
- 265 kW (355 hp) Tier 4i Mercedes OM501LA six-cylinder turbo-charged diesel engine. ZF, AS Tronic transmission
- MEGATRAK™ independent hydro-pneumatic suspension
- New Maniowoc Crane Control System
- New carrier cab

Features

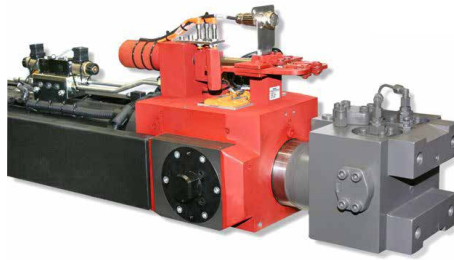

TWIN-LOCK™

Boom pinning mechanism automatically pins the sections in position using two horizontal pins.



Crane Control System

The new Crane Control System offers a user-friendly interface, two full graphic displays mounted vertically for better visibility, a jog dial for easier data input and ergonomic joysticks.

CraneSTAR

CraneSTAR is an exclusive and innovative crane asset management system that helps improve your profitability and reduce costs by remotely monitoring critical crane data. Visit www.cranestar.com for more information.

MEGATRAK™

The MEGATRAK™ suspension system is the best off road driveline available on the market today. The system's versatility and performance allows the GMK3060 to operate as a true all-terrain crane. The MEGATRAK™ independent suspension and all-wheel steer system allows wheels to remain on the ground at all times so stresses and weight are not continually transferred between axles. MEGATRAK™ provides true ground clearance where others just raise the chassis.

Other benefits of the MEGATRAK™ system are:

- A reliable suspension system
- Excellent job site maneuverability with all-wheel steering
- Commonality among almost all models
- A driveline that remains aligned at all times
- A steering linkage system that is protected against damage
- Constant tire contact for equal tire wear
- Reduced maintenance



Contents

Specifications	4
Dimensions	7
Counterweight	8
Transport proposal	9
Working range (main boom)	10
Load chart (main boom)	11
Working range (with swingaway)	19
Load chart (hydraulic offsettable swingaway)	20
Symbols glossary	26

Specifications

Superstructure

Boom

9,7 m – 43 m (32 ft – 141 ft) six section, full power boom with patented TWIN-LOCK™ boom pinning system. Maximum tip height: 45,8 m (150 ft).

Boom nose

Five nylatron sheaves, mounted on heavy duty tapered roller bearings with removable pin-type rope guards. Quick reeve boom nose. Removable auxiliary boom nose with removable pin type rope guard.

Boom elevation

Single lift cylinder with safety valve provides boom angle from -2.7° to $+82.8^\circ$.

Hydraulically offsettable lattice extension

8,7 m – 15 m (28.5 ft – 49.2 ft) bi-fold lattice swingaway extension hydraulically offsettable and luffing under load: 0° – 40° . Controlled from the crane cab.

Maximum tip height: 60,7 m (199 ft)

*Offsettable lattice extension

8,7 m – 15 m (28.5 ft – 49.2 ft) bi-fold lattice swingaway extension manually offset: 0° , 20° or 40° .

Maximum tip height: 60,7 m (199 ft)

Load moment and anti-two block system

Load moment and anti-two block system with audio/visual warning and control lever lockout provides electronic display of boom angle, length, radius, tip height, relative load moment, maximum permissible load, load indication and warning of impending two-block condition.

Cab

All aluminum construction cab with acoustical lining, tinted safety glass, adjustable operator's seat, sliding windows in side and cab rear, hinged front window with

wiper, sun visor and window shade. Other features include diesel heater/defroster, armrest integrated crane controls, and ergonomically arranged instrumentation.

Crane control system

Full electronic control of all crane movements using electrical control levers with automatic reset to zero. Controls are integrated with the LMI and engine management system by CAN-BUS.

Swing

Axial piston fixed displacement motor and planetary gear box. Infinitely variable to 2.5 rpm. Holding and service brake.

Counterweight

13 600 kg (29,983 lb) consisting of 6600 kg (14,500 lb) bolted to the turntable, 2 X 2000 kg (4409 lb) and 3 X 1000 kg (2204 lb) sections with hydraulic installation/removal system. Controlled from the superstructure cab.

Hydraulic system

2 separate circuits, 1 axial piston variable displacement pump (load sensing) with electronic power limiting control and 1 gear pump for swing.

Dual thermostatically controlled oil coolers keep oil at optimum operating temperature.

Tank capacity: 600 L (159 gal)

Hoist

Main and auxiliary hoist are powered by axial piston motor with planetary gear and brake. "Thumb-thumper" hoist drum rotation indicator alerts operator of hoist movement.

	Main	Auxiliary
Line length:	170 m (558 ft)	170 m (558 ft)
Rope diameter:	16 mm	16 mm
Line speed:	120 m/min (394 fpm)	120 m/min (394 fpm)
Line pull:	50 kN (11,240 lb)	50 kN (11,240 lb)

Specifications

Superstructure – continued

*Optional hook blocks

Lifting capacity	Sheaves	Weight	Parts of line	Possible load with the crane*
63 t (69 USt)	5	600 kg (1322 lb)	2-10/11*	60 t (65 USt*)
40 t (44 USt)	3	400 kg (880 lb)	2-7	35 t (38 USt)
16 t (17.6 USt)	1	250 kg (551 lb)	1-3	15 t (16.5 USt)
5 t (5.5USt)	H/B	100 kg (220 lb)	1	5 t (5.5 USt)

* Requires additional boom nose sheave

*Optional equipment

- Windspeed indicator
- Worklights mounted on base section
- Aircraft warning lights
- Hook blocks/headache ball
- Retractable cab foot walk
- Additional spotlight on superstructure cab
- Radio/CD player for superstructure cab
- Air conditioning – combined system for both cabs
- Additional strobe light for superstructure
- Working range limiter
- Wireless remote control for all crane functions (Hetricon)
- Automatic centralized lubrication for superstructure
- 360° positive swing lock

Carrier



Chassis

Box type, torsion resistant frame is fabricated from high strength steel.



Outrigger system

Four hydraulic single stage outrigger beams with vertical cylinders and outrigger pads, 500 mm (19.7 in) square. Outriggers can be set in 3 positions:

Full 6,2 m (20.3 ft)
 Partial 4,4 m (14.4 ft)
 Retracted 2,3 m (7.6 ft)

Independent horizontal and vertical movement

controlled from each side of carrier and the superstructure cab. Electronic crane level indicators.



Engine

Mercedes-Benz OM 501 LA six cylinder, water cooled, turbo-charged, with 265 kW (355 bhp) at 1800 rpm. Max. torque 1850 Nm (1365 ft/lb) at 1300 rpm. Compression and exhaust brakes.

Engine emissions: EUROMOT/EPA/CARB (off road) Tier 4i



Fuel tank capacity

300 L (79 gallons).



Transmission

ZF, AS Tronic, 12 speeds forward, 2 reverse.



Drive/steer

6x4x6



Axles

1st axle line – steer (optional drive)

2nd axle line – drive/steer

3rd axle line – drive/steer (connects for all wheel steer)

Drive axles with planetary hub reduction and center mounted gearing. Inter-axle and cross axle differential locks.



Suspension

Grove's exclusive MEGATRAK™ suspension. Independent hydro-pneumatic system acting on all wheels with hydraulic lockout. Suspension can be raised 170 mm (6.7 in) or lowered 130 mm (5.1 in) both longitudinally and transversely. Features an automatic leveling system for highway travel.



Tires

6 tires, 445/95 R25 (16.00 R25); vehicle width 2.75 m (9.0 ft)

Specifications

Carrier – continued



Steering

Dual circuit, hydraulic power assisted steering system. Transfer case mounted, ground driven emergency steering pump. Axles 1 and 2 steer on highway. Separate steering of the 3rd axle for all wheel and crab steering, controlled by an electric rocker switch.



Brakes

Service brakes: pneumatic dual circuit acting on all wheels.

Parking brake: pneumatically operated spring loaded brake acting on axle lines 1 and 3.

Air dryer.



Cab

Two-man, aluminum construction with the following features: safety glass, driver and passenger seats with pneumatic suspension, engine-dependent hot water heater, complete instrumentation and driving controls. Cab tilts forward for easy engine access.



Electrical system

24V system with three phase alternator, 28V/100A 2 batteries, 12V/170 Ah



Maximum speed

80 km/h (50 mph) 385/95 R25 tires
85 km/h (53 mph) 445/95 R25 / 525/80 R25 tires
(16.00 R25, 20.5 R25)



Gradeability (theoretical)

82% - 385/95 R25 tires (14.00 R25)
72% - 445/95 R25 / 525/80 R25 tires (16.00 R25/20.5 R25)

Miscellaneous standard equipment

Work light; tool kit; fire extinguisher; auxiliary boom nose; radio/CD player in carrier cab, heated rear view mirrors, and cruise control.

*Optional equipment

- Stainless steel exhaust system with spark arrestor
- Air conditioning – combined system for both cabs
- 385/95 R25 tires (14.00 R25) vehicle width 2,55 m (8.4 ft)
- 525/80 R25 tires (vehicle width 2,85 m [9.4 ft])
- 6x6x6 drive/steer
- Electric driveline retarder
- Engine independent diesel cab heater, with engine pre-heater
- Strobe light
- Worklights for outriggers
- Data logger
- Spare tire and wheel with carry bracket
- Engine shut down valve
- Outrigger pad load indicator
- Trailer hitch

Dimensions

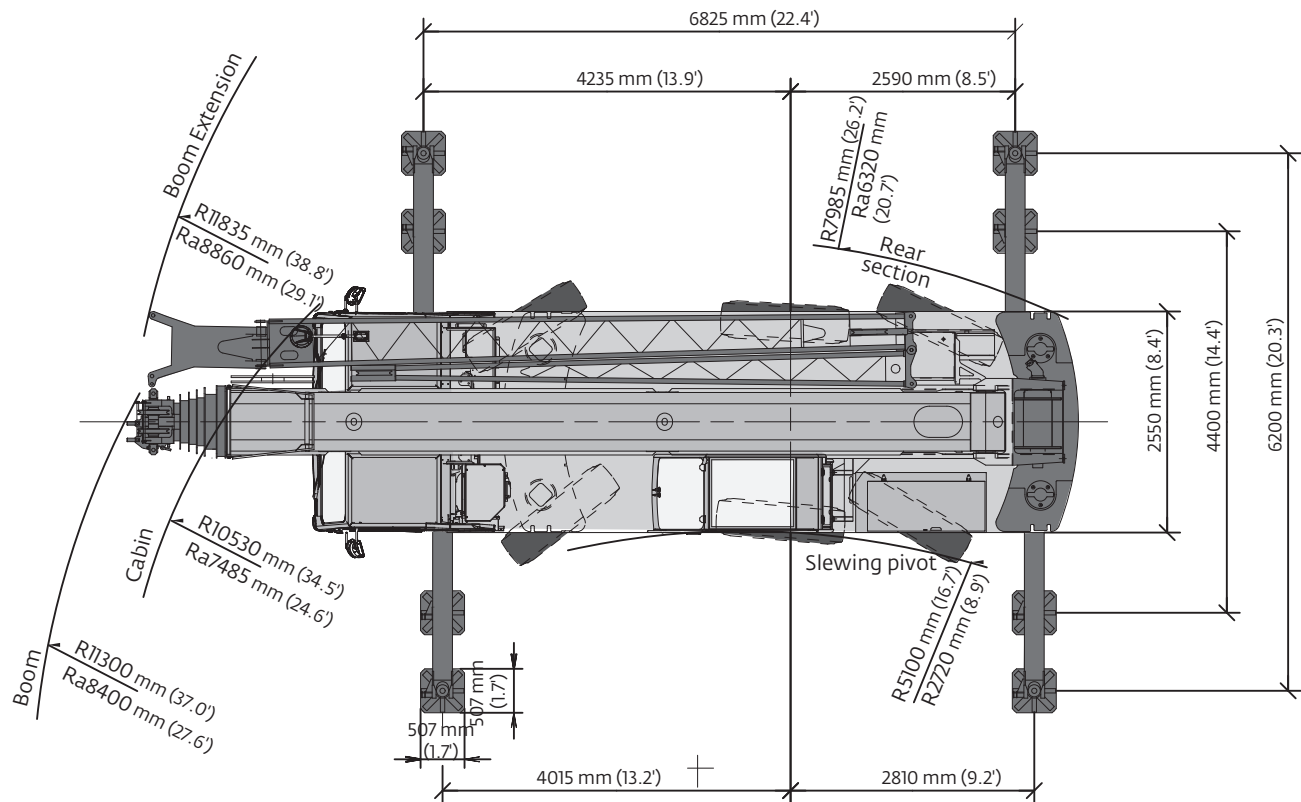
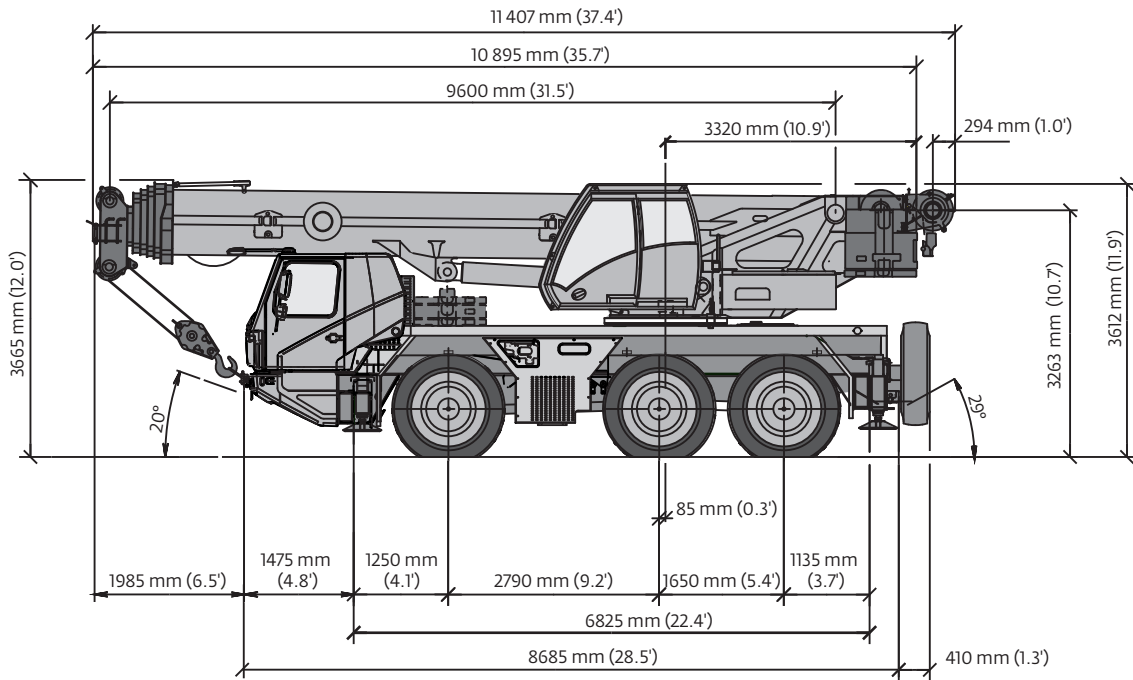

Counterweight

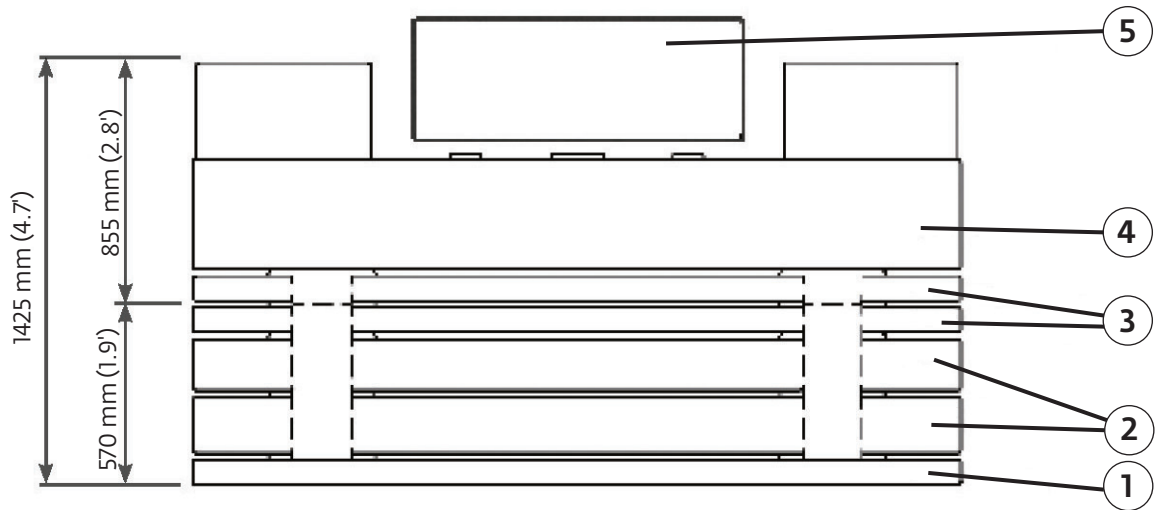

	① 1,0 t (1.1 USt)	② 2,0 t (2.2 USt)	③ 1,0 t (1.1 USt)	④* 5,6 t (6.2 USt)	⑤ 1,0 t (1.1 USt)**
6,6 t (7.3 USt)				X	X
7,6 t (8.4 USt)			X	X	X
8,6 t (9.5 USt)	X		X	X	X
9,6 t (10.6 USt)	X	X		X	X
10,6 t (11.7 USt)	X	X	X	X	X
11,6 t (12.8 USt)	X	2X		X	X
12,6 t (13.9 USt)	X	2X	X	X	X
13,6 t (15.0 USt)	X	2X	2X	X	X
*Fixed at turntable					
** Two 0,5 t (0.55 USt) or one 0,5 t (0.55 USt) + auxiliary hoist					

THIS CHART IS ONLY A GUIDE AND SHOULD NOT BE USED TO OPERATE THE CRANE.

The individual crane's load chart, operating instructions and other instructional plates must be read and understood prior to operating the crane.

Transport proposal

Boom over front

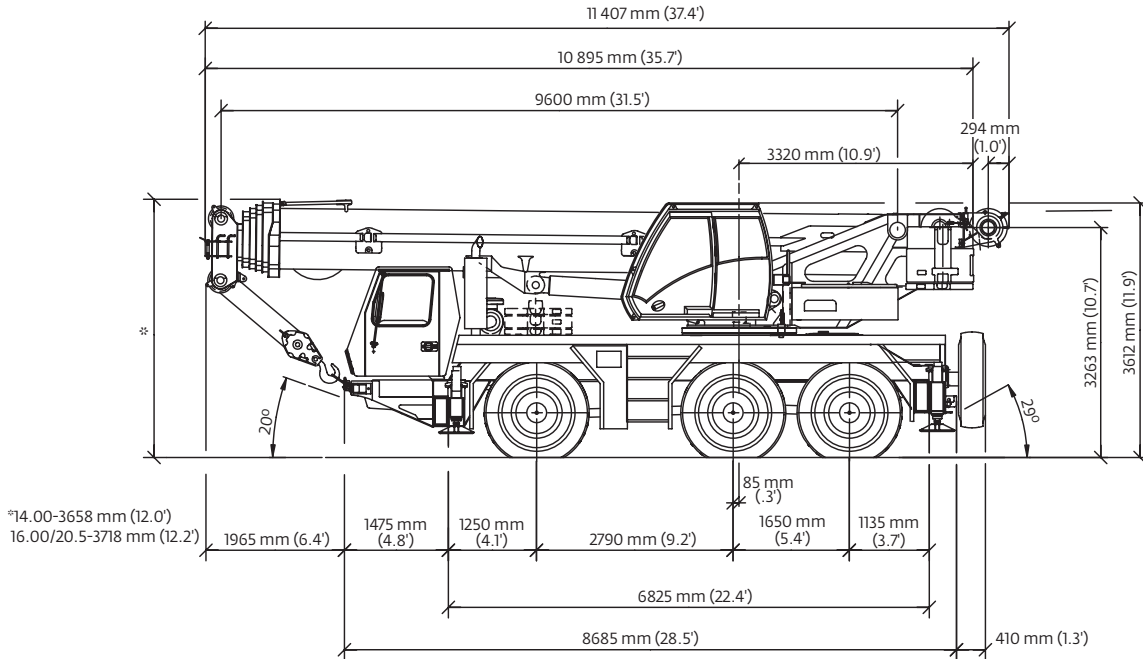

Boom over front

Basic weights - kg (lb)	Axle 1		Axles 2 and 3		Total	
Mercedes power, 28.5' - 49.2' hydraulic offset swingaway including brackets and hose reel, 16.00R25 tires, 6x4x6 drive/steer, 2nd oil cooler, outrigger pads, auxiliary hoist, 6600 kg (14,550 lb) counterweight fixed to superstructure, driver and tanks filled.	11 517	(25,391)	23 957	(52,815)	35 474	(78,206)
Additions:						
6x6x6 drive/steer	339	(748)	21	(46)	360	(794)
Electric driveline retarder	-17	(-37)	187	(412)	170	(375)
Spare wheel 14.00 R25 XGC steel rim with stowage	-179	(-394)	444	(979)	265	(584)
Spare wheel 16.00 R25 XGC steel rim with stowage	-218	(-482)	539	(1189)	321	(708)
Spare wheel 20.5 R25 XGC steel rim with stowage	-252	(-557)	620	(1368)	368	(811)
1000 kg (2200 lb) counterweight slab clamped to superstructure	-616	(-1359)	1656	(3651)	1040	(2293)
2000 kg (4400 lb) counterweight slab clamped to superstructure	-1227	(-2704)	3297	(7268)	2070	(4564)
1000 kg (2200 lb) counterweight slab on carrier deck (base plate)	1042	(2297)	-2	(-4)	1040	(2293)
2000 kg (4400 lb) counterweight slab on carrier deck	2074	(4572)	-4	(-9)	2070	(4564)
Substitutions:						
14.00R25 tires	133	(292)	265	(585)	-398	(877)
20.5R25 tires	94	(207)	188	(414)	282	(622)
Removals:						
Brackets for hydraulic swingaway	-71	(-157)	11	(24)	-60	(-132)
Hose reel for hydraulic swingaway	-120	(-265)	55	(122)	-65	(-143)
10 m - 17 m (33 ft - 56 ft) hydraulic swingaway	-1019	(-2247)	134	(296)	-885	(-1951)
Auxiliary boom nose	-128	(-283)	68	(151)	-60	(-132)
Outrigger floats front	-97	(-214)	25	(55)	-72	(-159)
Outrigger floats rear	38	(84)	-108	(-238)	-70	(-154)

THIS CHART IS ONLY A GUIDE AND SHOULD NOT BE USED TO OPERATE THE CRANE.

Working range

Main boom

9,7 m - 43 m (32 ft - 141 ft) main boom

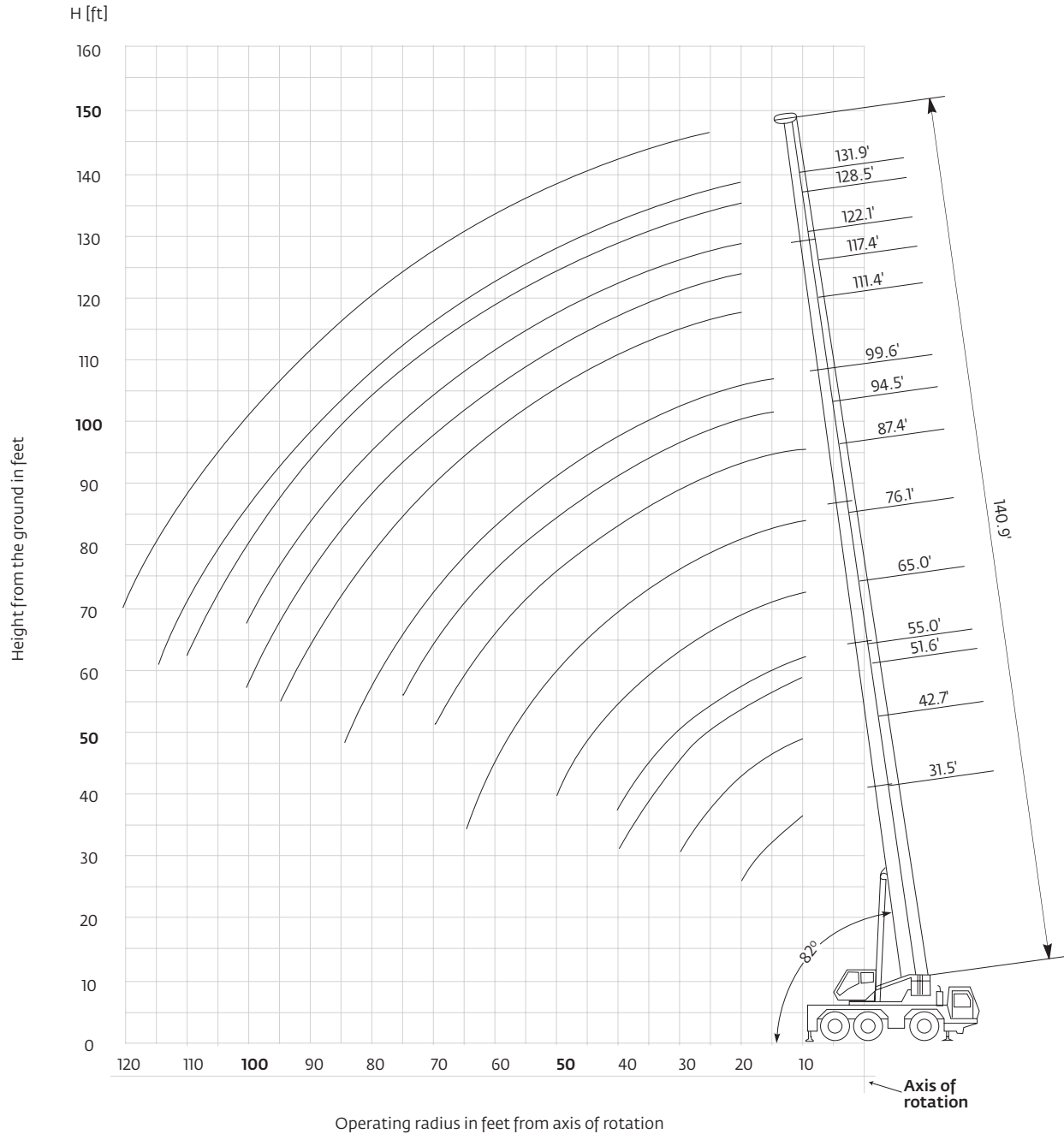

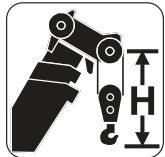
	Hook block	H
	55 USt, 5 sheave quick-reaving	3300 mm (10.8 ft)
	35 USt, 3 sheave quick-reaving	3200 mm (10.5 ft)
	15 USt, 1 sheave quick-reaving	3100 mm (10.2 ft)
	5 USt single headache ball	2700 mm (8.9 ft)

Tip heights shown in the working range diagram do not consider loaded boom deflection.

Load chart

Main boom

9,7 m – 43,0 m
 (32 ft – 141 ft)

13 600 kg
 (29,900 lb)

6,8 m x 6,2 m
 (22.4 ft x 20.4 ft)
 100%

360°



Pounds x 1000

Feet	32	43	54	65	76	89	100	111	122	132	141
8	130.00 **/ 120.00 *										
9	114.00 *										
10	106.00 *	102.00	95.00	88.00	74.00	54.00					
15	83.00	80.00	77.00	71.00	64.00	47.00	42.00				
20	62.00	63.00	62.00	58.00	54.00	41.00	36.80	32.60	26.20	20.80	
25		49.00	49.00	48.00	46.00	36.20	32.00	29.20	25.60	20.80	17.60
30		39.40	39.40	36.80	36.40	32.20	27.20	25.80	23.60	20.80	17.60
35			31.60	31.20	29.60	29.00	23.40	22.20	21.20	19.20	17.60
40			26.40	26.40	24.60	24.80	20.80	19.80	19.20	17.80	16.40
45				21.80	21.80	21.20	18.40	17.60	17.00	16.40	15.20
50				18.40	19.20	18.20	16.40	15.60	15.20	15.00	14.20
55					16.60	16.00	14.80	14.00	13.60	13.40	13.00
60					14.40	13.80	12.80	12.60	12.00	12.00	11.80
65					12.60	12.00	11.40	11.00	10.60	10.40	10.60
70						10.40	9.80	9.60	9.60	9.60	9.60
75						7.60	8.60	8.60	8.60	8.80	9.00
80							7.40	7.40	7.60	7.80	8.00
85							6.40	6.40	6.60	7.00	7.20
90								5.60	5.80	6.20	6.40
95								4.80	5.00	5.40	5.80
100									4.40	4.60	5.00
105										4.00	4.40
110										3.60	3.80
115										3.00	3.40
120											3.00

**Over rear with special equipment

*Over rear

THIS CHART IS ONLY A GUIDE AND SHOULD NOT BE USED TO OPERATE THE CRANE.

Load chart

Main boom



9,7 m – 43,0 m
(32 ft – 141 ft)



12 600 kg
(27,700 lb)



6,8 m x 6,2 m
(22.4 ft x 20.4 ft)
100%



360°



Pounds x 1000

Feet	32	43	54	65	76	89	100	111	122	132	141
8	120.00 *										
9	114.00 *										
10	106.00 *	102.00	95.00	88.00	74.00	54.00					
15	83.00 *	79.00	77.00	71.00	64.00	47.00	42.00				
20	61.00	62.00	61.00	58.00	54.00	41.00	36.80	32.60	26.20	20.80	
25		48.00	48.00	46.00	45.00	36.20	32.00	29.20	25.60	20.80	17.60
30		38.80	37.80	35.80	35.00	32.20	27.20	25.80	23.60	20.80	17.60
35			31.00	30.20	28.40	28.40	23.40	22.20	21.20	19.20	17.60
40			25.40	25.20	23.80	23.80	20.80	19.80	19.20	17.80	16.40
45				20.80	21.60	20.20	18.40	17.60	17.00	16.40	15.20
50				17.60	18.40	17.40	16.20	15.60	15.20	15.00	14.20
55					15.80	15.20	14.00	13.60	13.40	13.40	13.00
60					13.80	13.20	12.20	11.80	11.80	12.00	11.80
65					12.00	11.40	10.60	10.40	10.20	10.40	10.60
70						9.80	9.20	9.00	9.00	9.20	9.40
75						7.00	8.00	8.00	8.00	8.20	8.40
80							6.80	6.80	7.00	7.20	7.40
85							6.00	5.80	6.00	6.40	6.60
90								5.00	5.20	5.60	6.00
95								4.40	4.60	5.00	5.20
100									3.80	4.20	4.60
105										3.60	4.00
110										3.20	3.40
115										2.60	3.00
120											2.60

*Over rear

THIS CHART IS ONLY A GUIDE AND SHOULD NOT BE USED TO OPERATE THE CRANE.

The individual crane's load chart, operating instructions and other instructional plates must be read and understood prior to operating the crane.

Load chart

Main boom





9,7 m – 43,0 m
 (32 ft – 141 ft)

11 600 kg
 (25,500 lb)

6,8 m x 6,2 m
 (22.4 ft x 20.4 ft)
 100%

360°



 Pounds x 1000

Feet	32	43	54	65	76	89	100	111	122	132	141
8	120.00 *										
9	114.00 *										
10	103.00	102.00	95.00	88.00	74.00	54.00					
15	79.00	79.00	77.00	71.00	64.00	47.00	42.00				
20	60.00	61.00	60.00	58.00	54.00	41.00	36.80	32.60	26.20	20.80	
25		47.00	47.00	43.80	42.80	36.20	32.00	29.20	25.60	20.80	17.60
30		37.20	36.20	35.60	33.40	32.20	27.20	25.80	23.60	20.80	17.60
35			30.20	29.00	27.00	27.20	23.40	22.20	21.20	19.20	17.60
40			24.20	24.00	23.80	27.20	20.80	19.80	19.20	17.80	16.40
45				20.00	20.60	22.60	18.00	17.40	17.00	16.40	15.20
50				17.40	17.60	19.20	15.40	14.80	14.80	14.80	14.20
55					15.00	16.60	13.20	12.80	12.80	12.80	13.00
60					13.00	14.40	11.40	11.20	11.00	11.20	11.40
65					11.40	12.40	10.00	9.60	9.60	9.80	10.00
70						10.60	8.60	8.40	8.40	9.20	8.80
75						9.20	7.40	7.40	7.40	8.60	7.80
80						6.40	6.20	6.20	6.40	7.80	7.00
85							5.40	5.40	5.60	6.80	6.20
90								4.60	4.80	6.20	5.40
95								3.80	4.00	5.40	4.80
100									3.40	4.80	4.20
105										4.20	3.60
110										3.60	3.20
115										2.20	2.60
120											2.20

*Over rear

Load chart

Main boom



9,7 m - 43,0 m
(32 ft - 141 ft)



10 600 kg
(23,300 lb)



6,8 m x 6,2 m
(22.4 ft x 20.4 ft)
100%



360°



Pounds x 1000

Feet	32	43	54	65	76	89	100	111	122	132	141
10	103.00	102.00	95.00	88.00	74.00	54.00					
15	79.00	79.00	77.00	71.00	64.00	47.00	42.00				
20	60.00	60.00	59.00	57.00	54.00	41.00	36.80	32.60	26.20	20.80	
25		47.00	45.00	41.80	41.00	36.20	32.00	29.20	25.60	20.80	17.60
30		35.40	35.40	34.00	32.00	31.80	27.20	25.80	23.60	20.80	17.60
35			28.80	27.60	26.40	26.00	23.40	22.20	21.20	19.20	17.60
40			23.20	22.80	23.00	21.60	20.20	19.40	19.20	17.80	16.40
45				19.00	19.60	18.20	17.00	16.40	16.20	16.40	15.20
50				17.00	16.80	15.60	14.40	14.00	13.80	14.00	14.20
55					14.20	13.60	12.40	12.00	12.00	12.40	12.20
60					12.20	11.60	10.60	10.40	10.40	11.00	10.60
65					10.60	10.00	9.20	9.00	9.00	9.80	9.40
70						8.60	8.00	7.80	8.40	9.00	8.20
75						5.80	7.40	6.80	7.80	8.00	7.20
80							5.80	5.80	7.20	7.20	6.40
85							4.80	4.80	6.60	6.40	5.60
90								4.20	5.80	5.60	5.00
95								3.40	5.20	5.00	4.40
100									4.60	4.40	3.80
105										3.80	3.20
110										3.20	2.80
115										2.00	2.20
120											1.80

THIS CHART IS ONLY A GUIDE AND SHOULD NOT BE USED TO OPERATE THE CRANE.

The individual crane's load chart, operating instructions and other instructional plates must be read and understood prior to operating the crane.

Load chart

Main boom

 9,7 m – 43,0 m
 (32 ft – 141 ft)

 9600 kg
 (21,100 lb)

 6,8 m x 6,2 m
 (22.4 ft x 20.4 ft)
 100%

 360°



Pounds x 1000

Feet	32	43	54	65	76	89	100	111	122	132	141
10	103.00	102.00	95.00	88.00	74.00	54.00					
15	79.00	79.00	77.00	71.00	64.00	47.00	42.00				
20	59.00	59.00	57.00	54.00	53.00	41.00	36.80	32.60	26.20	20.80	
25		46.00	42.80	39.80	39.20	36.20	32.00	29.20	25.60	20.80	17.60
30		33.80	34.40	32.60	30.40	30.20	27.20	25.80	23.60	20.80	17.60
35			27.40	26.20	26.40	24.60	23.00	22.20	21.20	19.20	17.60
40			22.00	21.80	22.00	20.40	19.00	18.40	18.20	17.80	16.40
45				19.00	18.60	17.40	16.00	15.60	15.40	15.40	15.20
50				16.20	15.80	14.80	13.60	13.20	13.00	13.20	13.20
55					13.40	12.80	11.60	11.20	11.40	11.20	11.40
60					11.60	10.80	10.00	9.60	10.20	9.80	10.00
65					10.00	9.20	8.60	8.20	9.00	8.40	8.60
70						8.00	7.20	7.20	8.40	7.40	7.60
75						5.20	6.20	6.20	7.80	6.40	6.60
80							5.20	5.20	7.00	5.60	5.80
85							4.40	4.40	6.20	4.80	5.00
90								3.60	5.40	4.20	4.40
95								3.00	4.80	3.60	3.80
100									4.20	3.00	3.40
105										2.40	2.80
110										2.00	2.40
115										1.60	2.00
120											1.60

Load chart

Main boom



9,7 m - 43,0 m
(32 ft - 141 ft)



8600 kg
(18,900 lb)



6,8 m x 6,2 m
(22.4 ft x 20.4 ft)
100%



360°





Pounds x 1000

Feet	32	43	54	65	76	89	100	111	122	132	141
10	103.00	102.00	95.00	88.00	74.00	54.00					
15	78.00	79.00	77.00	71.00	64.00	47.00	42.00				
20	58.00	58.00	56.00	52.00	50.00	41.00	36.80	32.60	26.20	20.80	
25		43.40	40.80	40.00	37.20	36.20	32.00	29.20	25.60	20.80	17.60
30		32.80	32.60	31.00	29.60	28.80	26.80	25.80	23.60	20.80	17.60
35			26.00	25.00	25.00	23.40	21.80	21.00	20.60	19.20	17.60
40			20.80	20.80	20.80	19.40	18.00	17.40	17.00	17.20	16.40
45				18.20	17.60	16.20	15.00	14.60	14.40	15.00	14.60
50				15.20	15.00	13.80	12.60	12.20	12.00	13.40	12.40
55					12.60	11.80	10.80	10.40	10.20	11.60	10.60
60					10.80	10.00	9.40	8.80	8.80	10.20	9.20
65					9.20	8.60	8.80	7.60	7.60	8.80	8.00
70						7.40	8.00	6.40	6.40	7.80	7.00
75						4.60	7.40	5.60	5.60	6.80	6.00
80							4.60	4.60	4.80	6.00	5.20
85							3.80	3.80	4.00	5.40	4.60
90								3.20	3.40	4.60	4.00
95								2.60	2.80	4.00	3.40
100									2.20	3.40	3.00
105										3.00	2.40
110										2.60	2.00
115											1.60

Load chart

Main boom

9,7 m - 43,0 m
 (32 ft - 141 ft)

7600 kg
 (16,700 lb)

6,8 m x 6,2 m
 (22.4 ft x 20.4 ft)
 100%

360°



Feet	32	43	54	65	76	89	100	111	122	132	141
10	102.00	102.00	95.00	88.00	74.00	54.00					
15	78.00	79.00	77.00	71.00	64.00	47.00	42.00				
20	57.00	57.00	54.00	49.00	48.00	41.00	36.80	32.60	26.20	20.80	
25		41.40	40.40	38.00	35.60	35.00	32.00	29.20	25.60	20.80	17.60
30		31.00	31.00	29.40	29.20	27.40	25.40	24.40	23.60	20.80	17.60
35			24.60	23.60	23.80	22.20	20.60	19.80	19.40	19.20	17.60
40			19.40	20.80	19.60	18.20	16.80	16.20	16.00	16.00	16.00
45				17.20	16.60	15.20	14.00	13.40	14.20	13.40	13.60
50				14.40	14.00	12.80	11.80	11.40	12.60	11.40	11.60
55					11.80	11.00	10.60	9.60	11.40	9.60	9.80
60					10.00	9.40	9.40	8.00	9.80	8.20	8.40
65					8.60	8.00	8.80	6.80	8.60	7.20	7.40
70						6.80	8.00	5.80	7.60	6.00	6.40
75						4.20	7.40	5.00	6.60	5.20	5.40
80							4.20	4.20	5.80	4.40	4.80
85							3.40	3.40	5.20	3.80	4.00
90								2.60	4.40	3.20	3.40
95								2.00	3.80	2.60	3.00
100									3.40	2.20	2.40
105										1.60	2.00
110											1.60

Load chart

Main boom



9,7 m – 43,0 m
(32 ft – 141 ft)



6600 kg
(14,500 lb)



6,8 m x 6,2 m
(22.4 ft x 20.4 ft)
100%



360°



Pounds x 1000

Feet	32	43	54	65	76	89	100	111	122	132	141
10	102.00	102.00	95.00	88.00	74.00	54.00					
15	78.00	78.00	77.00	71.00	64.00	47.00	42.00				
20	56.00	55.00	51.00	49.00	45.00	41.00	36.80	32.60	26.20	20.80	
25		39.20	38.40	36.20	33.60	33.20	30.80	29.20	25.60	20.80	17.60
30		29.20	29.40	27.80	27.80	25.80	24.00	23.00	22.40	20.80	17.60
35			23.00	23.40	22.40	20.80	19.20	18.40	18.20	18.00	17.60
40			18.20	19.60	18.40	17.00	15.60	15.00	15.80	16.20	15.00
45				16.00	15.40	14.20	13.20	12.40	14.20	13.60	12.60
50				13.40	13.00	11.80	11.80	10.40	12.20	11.60	10.60
55					11.00	10.00	10.60	8.80	10.60	10.00	9.00
60					9.20	8.60	9.40	7.40	9.20	8.60	7.80
65					7.80	7.20	8.80	6.20	8.00	7.40	6.60
70						6.00	7.80	5.20	7.00	6.40	5.60
75						3.60	6.80	4.40	6.00	5.60	4.80
80							3.60	3.60	5.40	5.00	4.20
85							2.80	2.80	4.60	4.20	3.60
90								2.20	4.00	3.60	3.00
95								1.60	3.40	3.20	2.40
100									2.80	2.60	2.00
105										2.20	1.60
110										1.80	

THIS CHART IS ONLY A GUIDE AND SHOULD NOT BE USED TO OPERATE THE CRANE.

The individual crane's load chart, operating instructions and other instructional plates must be read and understood prior to operating the crane.

Working range

Hydraulic offsettable swingaway

9,7 m - 43 m (32 ft - 141 ft) main boom with 8,7 m - 15 m (28.5 ft - 49.2 ft) swingaway

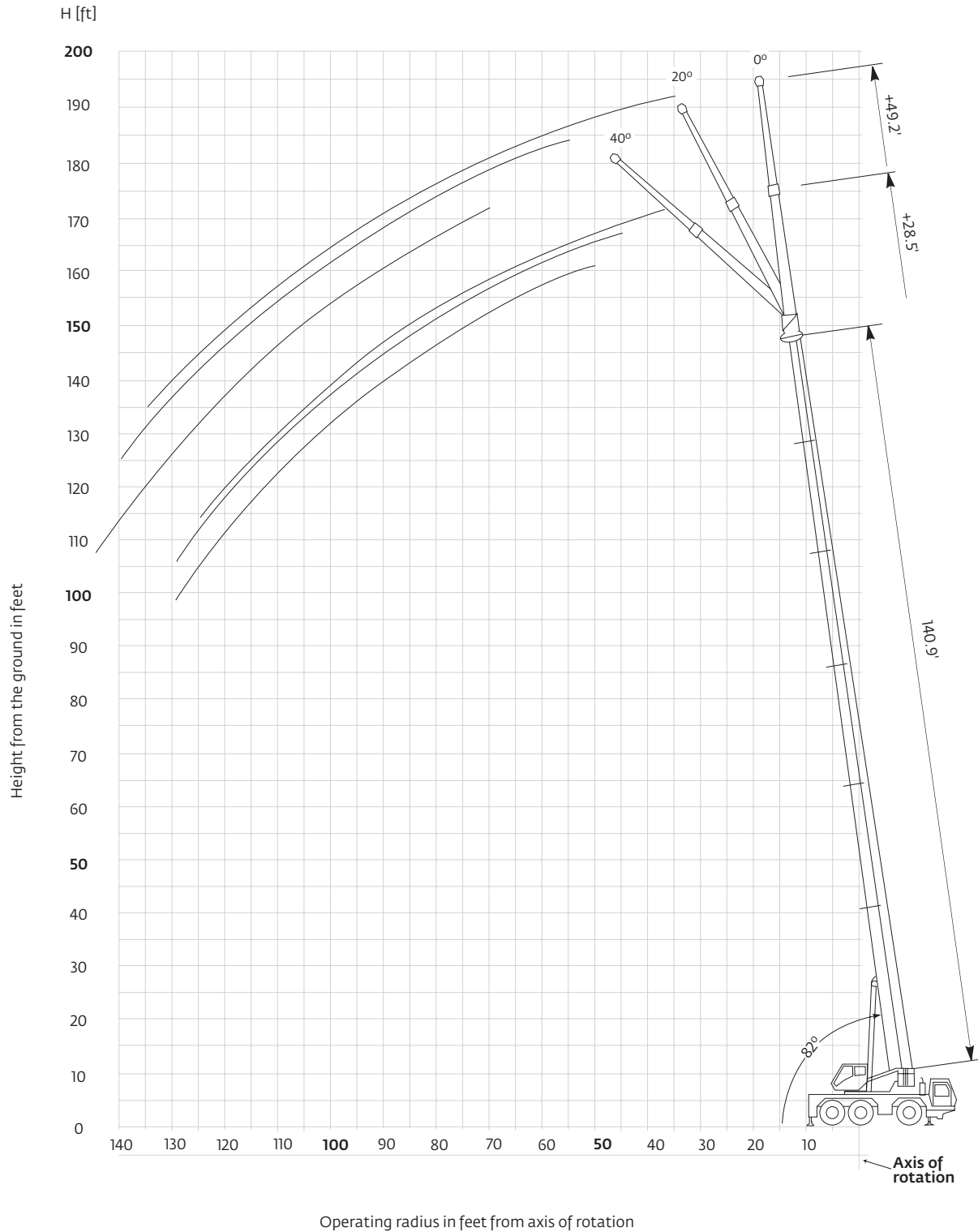

Tip heights shown in the working range diagram do not consider loaded boom deflection.

THIS CHART IS ONLY A GUIDE AND SHOULD NOT BE USED TO OPERATE THE CRANE.

Load chart

Hydraulic offsettable swingaway



40,2 m - 43,0 m
(131.9 ft - 140.9 ft)



8,7 m
(28.5 ft)



13,600 kg
(29,900 lb)



6,8 m x 6,2 m
(22.4 ft x 20.4 ft)
100%



360°



Pounds x 1000

Feet	132 28.5					141 28.5				
	0°	20°	40°	*0° - 20°	*20° - 40°	0°	20°	40°	*0° - 20°	*20° - 40°
30	11.2									
35	11.2					9.4				
40	11.2	9.6		5.6		9.4				
45	10.8	9.2		5.2		9.4	8.8		5.4	
50	10.6	9.0	7.6	5.0	4.2	9.4	8.8	7.4	5.2	4.2
55	10.0	8.8	7.4	4.8	4.0	8.8	8.2	7.4	5.0	4.0
60	9.4	8.4	7.2	4.6	4.0	8.2	7.8	7.2	4.8	4.0
65	8.8	8.2	7.2	4.4	3.8	7.8	7.4	7.2	4.6	3.8
70	8.4	7.8	7.0	4.4	3.8	7.4	7.0	6.8	4.4	3.8
75	7.8	7.6	7.0	4.2	3.8	7.0	6.6	6.6	4.2	3.8
80	7.2	7.2	6.8	4.0	3.6	6.6	6.4	6.2	4.2	3.8
85	6.6	6.6	6.8	4.0	3.6	6.2	6.0	6.0	4.0	3.6
90	5.8	5.8	6.2	3.8	3.6	6.0	5.8	5.8	4.0	3.6
95	5.2	5.2	5.6	3.8	3.6	5.2	5.2	5.4	3.8	3.6
100	4.8	5.0	5.0	3.6	3.6	4.8	4.8	5.0	3.8	3.6
105	4.6	4.6	4.8	3.6	3.6	4.2	4.2	4.4	3.6	3.6
110	4.2	4.4	4.4	3.4	3.4	3.6	3.6	4.0	3.4	3.6
115	3.8	3.8	4.0	3.4	3.4	3.2	3.2	3.4	3.0	3.2
120	3.4	3.4	3.6	3.0	3.2	2.8	2.8	3.0	2.6	2.8
125	3.0	3.0	3.2	2.8	2.8	2.4	2.4	2.6	2.2	2.4
130	2.6	2.6	2.6	2.4	2.4	2.0	2.0	2.2	1.8	2.0
135	2.2	2.2	2.4	2.0	2.2	1.6	1.6	1.8	1.6	1.6
140						1.4	1.4	1.4		1.4





*Luffing under load

THIS CHART IS ONLY A GUIDE AND SHOULD NOT BE USED TO OPERATE THE CRANE.

The individual crane's load chart, operating instructions and other instructional plates must be read and understood prior to operating the crane.

Load chart

Hydraulic offsettable swingaway

40,2 m - 43,0 m
(131.9 ft - 140.9 ft)

15,0 m
(49.2 ft)

13,600 kg
(29,900 lb)

6,8 m x 6,2 m
(22.4 ft x 20.4 ft)
100%

360°



Pounds x 1000

Feet	132 49.2					141 49.2				
	0°	20°	40°	*0° - 20°	*20° - 40°	0°	20°	40°	*0° - 20°	*20° - 40°
30	6.4									
35	6.2					5.6				
40	6.2					5.6				
45	6.2					5.6				
50	6.0	5.2		2.8		5.6				
55	6.0	5.0		2.6		5.6	4.8		2.8	
60	6.0	4.8		2.6		5.4	4.8		2.6	
65	5.8	4.6		2.4		5.4	4.6		2.4	
70	5.6	4.6	3.8	2.4	1.8	5.4	4.4	3.8	2.4	1.8
75	5.2	4.4	3.6	2.2	1.8	5.2	4.4	3.6	2.2	1.8
80	5.0	4.2	3.6	2.2	1.8	5.0	4.2	3.6	2.0	1.8
85	5.0	4.2	3.6	2.0	1.8	4.8	4.2	3.6	2.0	1.8
90	4.8	4.0	3.6	2.0	1.8	4.6	4.0	3.6	2.0	1.8
95	4.6	4.0	3.4	1.8	1.6	4.6	4.0	3.4	2.0	1.6
100	4.4	3.8	3.4	1.8	1.6	4.4	3.8	3.4	1.8	1.6
105	4.2	3.8	3.4	1.8	1.6	4.2	3.8	3.4	1.8	1.6
110	4.0	3.6	3.4	1.6	1.6	4.0	3.6	3.4	1.8	1.6
115	3.6	3.4	3.4	1.6	1.6	3.6	3.6	3.4	1.6	1.6
120	3.4	3.2	3.4	1.6	1.6	3.2	3.2	3.2	1.6	1.6
125	3.2	3.0	3.2	1.6	1.6	2.8	2.8	3.2	1.6	1.6
130	3.0	2.6	3.2	1.6	1.6	2.4	2.4	2.8	1.6	1.6
135	2.6	2.4	3.0	1.4	1.4	2.0	2.0	2.6	1.6	1.6
140	2.4	2.0	2.6	1.4	1.4	1.8	1.8	2.2	1.4	1.4
145	2.0	1.8	2.2	1.4	1.4	1.4	1.4	1.8	1.4	1.4
150	1.8	1.4	2.0	1.4	1.4			1.4		
155	1.4		1.6							

**Luffing under load*

THIS CHART IS ONLY A GUIDE AND SHOULD NOT BE USED TO OPERATE THE CRANE.

Load chart

Hydraulic offsettable swingaway



40,2 m - 43,0 m
(131.9 ft - 140.9 ft)



8,7 m
(28.5 ft)



11,600 kg
(25,500 lb)



6,8 m x 6,2 m
(22.4 ft x 20.4 ft)
100%



360°



Pounds x 1000

Feet	132 28.5					141 28.5				
	0°	20°	40°	*0° - 20°	*20° - 40°	0°	20°	40°	*0° - 20°	*20° - 40°
30	11.2									
35	11.2					9.4				
40	11.2	9.6		5.6		9.4				
45	10.8	9.2		5.2		9.4	8.8		5.4	
50	10.6	9.0	7.6	5.0	4.2	9.4	8.8	7.4	5.2	4.2
55	10.0	8.8	7.4	4.8	4.0	8.8	8.2	7.4	5.0	4.0
60	9.4	8.4	7.2	4.6	4.0	8.2	7.8	7.2	4.8	4.0
65	8.8	8.2	7.2	4.4	3.8	7.8	7.4	7.2	4.6	3.8
70	8.2	7.8	7.0	4.4	3.8	7.4	7.0	6.8	4.4	3.8
75	7.2	7.2	7.0	4.2	3.8	7.0	6.6	6.6	4.2	3.8
80	6.4	6.4	6.8	4.0	3.6	6.4	6.4	6.2	4.2	3.8
85	6.0	5.8	6.0	4.0	3.6	5.6	5.6	6.0	4.0	3.6
90	5.6	5.6	5.6	3.8	3.6	5.0	5.0	5.4	4.0	3.6
95	5.2	5.2	5.2	3.8	3.6	4.4	4.4	4.8	3.8	3.6
100	4.6	4.6	4.8	3.6	3.6	3.8	3.8	4.2	3.8	3.6
105	4.0	4.0	4.4	3.6	3.6	3.4	3.4	3.6	3.2	3.6
110	3.6	3.6	3.8	3.2	3.4	2.8	2.8	3.2	2.8	3.0
115	3.0	3.0	3.4	2.8	3.0	2.4	2.4	2.8	2.4	2.6
120	2.6	2.6	2.8	2.4	2.6	2.0	2.0	2.4	2.0	2.2
125	2.2	2.2	2.4	2.0	2.2	1.6	1.6	2.0	1.6	1.8
130	2.0	2.0	2.0	1.8	1.8	1.4	1.4	1.6		1.4
135	1.6	1.6	1.6	1.4	1.6					





*Luffing under load

THIS CHART IS ONLY A GUIDE AND SHOULD NOT BE USED TO OPERATE THE CRANE.

The individual crane's load chart, operating instructions and other instructional plates must be read and understood prior to operating the crane.

Load chart

Hydraulic offsettable swingaway

 40,2 m - 43,0 m
 (131.9 ft - 140.9 ft)
  15,0 m
 (49.2 ft)
  11,600 kg
 (25,500 lb)
  6,8 m x 6,2 m
 (22.4 ft x 20.4 ft)
 100%
  360°



 Pounds x 1000

Feet	132 49.2					141 49.2				
	0°	20°	40°	*0° - 20°	*20° - 40°	0°	20°	40°	*0° - 20°	*20° - 40°
30	6.4									
35	6.2					5.6				
40	6.2					5.6				
45	6.2					5.6				
50	6.0	5.2		2.8		5.6				
55	6.0	5.0		2.6		5.6	4.8		2.8	
60	6.0	4.8		2.6		5.4	4.8		2.6	
65	5.8	4.6		2.4		5.4	4.6		2.4	
70	5.6	4.6	3.8	2.4	1.8	5.4	4.4	3.8	2.4	1.8
75	5.2	4.4	3.6	2.2	1.8	5.2	4.4	3.6	2.2	1.8
80	5.0	4.2	3.6	2.2	1.8	5.0	4.2	3.6	2.2	1.8
85	5.0	4.2	3.6	2.0	1.8	4.8	4.2	3.6	2.0	1.8
90	4.8	4.0	3.6	2.0	1.8	4.6	4.0	3.6	2.0	1.8
95	4.6	4.0	3.4	1.8	1.6	4.6	4.0	3.4	2.0	1.6
100	4.2	3.8	3.4	1.8	1.6	4.2	3.8	3.4	1.8	1.6
105	4.0	3.6	3.4	1.8	1.6	3.6	3.6	3.4	1.8	1.6
110	3.8	3.6	3.4	1.8	1.6	3.2	3.2	3.4	1.8	1.6
115	3.4	3.4	3.4	1.6	1.6	2.8	2.8	3.4	1.6	1.6
120	3.2	3.2	3.4	1.6	1.6	2.4	2.4	3.0	1.6	1.6
125	2.8	2.8	3.2	1.6	1.6	2.2	2.2	2.6	1.6	1.6
130	2.4	2.4	2.8	1.6	1.6	1.8	1.8	2.2	1.6	1.6
135	2.0	2.0	2.4	1.4	1.4	1.4	1.4	1.8	1.4	1.6
140	1.8	1.8	2.0	1.4	1.4			1.6		1.4
145	1.4	1.4	1.6	1.4	1.4					
150			1.4		1.4					

*Luffing under load

THIS CHART IS ONLY A GUIDE AND SHOULD NOT BE USED TO OPERATE THE CRANE.

Load chart

Hydraulic offsettable swingaway



40,2 m - 43,0 m
(131.9 ft - 140.9 ft)



8,7 m
(28.5 ft)



6600 kg
(14,500 lb)



6,8 m x 6,2 m
(22.4 ft x 20.4 ft)
100%



360°



Pounds x 1000

Feet	132 28.5					141 28.5				
	0°	20°	40°	° 0° - 20°	° 20° - 40°	0°	20°	40°	*0° - 20°	*20° - 40°
30	11.2									
35	11.2					9.4				
40	11.2	9.6		5.6		9.4				
45	10.8	9.2		5.2		9.4	8.8		5.4	
50	10.0	9.0	7.6	5.0	4.2	9.4	8.8	7.4	5.2	4.2
55	8.6	8.4	7.4	4.8	4.0	8.4	8.2	7.4	5.0	4.0
60	8.0	7.6	7.2	4.6	4.0	7.2	7.2	7.2	4.8	4.0
65	7.0	7.0	7.0	4.4	3.8	6.2	6.2	6.8	4.6	3.8
70	6.0	6.0	6.6	4.4	3.8	5.2	5.2	5.8	4.4	3.8
75	5.2	5.2	5.8	4.2	3.8	4.4	4.4	5.0	4.2	3.8
80	4.6	4.6	5.0	4.0	3.6	3.8	3.8	4.2	3.8	3.8
85	3.8	3.8	4.2	3.8	3.6	3.2	3.2	3.6	3.2	3.6
90	3.4	3.4	3.6	3.4	3.6	2.6	2.6	3.0	2.6	3.0
95	2.8	2.8	3.2	2.8	3.0	2.2	2.2	2.4	2.2	2.4
100	2.4	2.4	2.6	2.4	2.6	1.6	1.6	2.0	1.6	2.0
105	2.0	2.0	2.2	2.0	2.2			1.6		1.6
110	1.6	1.6	1.8	1.6	1.8					
115			1.4		1.4					





*Luffing under load

THIS CHART IS ONLY A GUIDE AND SHOULD NOT BE USED TO OPERATE THE CRANE.

The individual crane's load chart, operating instructions and other instructional plates must be read and understood prior to operating the crane.

Load chart

Hydraulic offsettable swingaway

40,2 m - 43,0 m
 (131.9 ft - 140.9 ft)

15,0 m
 (49.2 ft)

6600 kg
 (14,500 lb)

6,8 m x 6,2 m
 (22.4 ft x 20.4 ft)
 100%

360°



 Pounds x 1000

Feet	132 49.2					141 49.2				
	0°	20°	40°	*0° - 20°	*20° - 40°	0°	20°	40°	*0° - 20°	*20° - 40°
30	6.4									
35	6.2					5.6				
40	6.2					5.6				
45	6.2					5.6				
50	6.0	5.2		2.8		5.6				
55	6.0	5.0		2.6		5.6	4.8		2.8	
60	6.0	4.8		2.6		5.4	4.8		2.6	
65	5.8	4.6		2.4		5.4	4.6		2.4	
70	5.6	4.6	3.8	2.4	1.8	5.4	4.4	3.8	2.4	1.8
75	5.2	4.4	3.6	2.2	1.8	4.8	4.4	3.6	2.2	1.8
80	4.8	4.2	3.6	2.2	1.8	4.2	4.2	3.6	2.2	1.8
85	4.2	4.0	3.6	2.0	1.8	3.4	3.4	3.6	2.0	1.8
90	3.6	3.6	3.6	2.0	1.8	3.0	3.0	3.6	2.0	1.8
95	3.2	3.2	3.4	1.8	1.6	2.4	2.4	3.2	2.0	1.6
100	2.8	2.8	2.8	1.8	1.6	2.0	2.0	2.8	1.8	1.6
105	2.4	2.4	2.4	1.8	1.6	1.6	1.6	2.2	1.6	1.6
110	2.0	2.0	2.0	1.6	1.6	1.2	1.2	1.8	1.2	1.6
115	1.6	1.6	1.8	1.6	1.6			1.4		1.4
120	1.4	1.4	1.4		1.6					
125					1.4					

*Luffing under load

THIS CHART IS ONLY A GUIDE AND SHOULD NOT BE USED TO OPERATE THE CRANE.

Symbols glossary



Axles



Counterweight



Grade



Outriggers



Boom



Drive



Heavy duty jib



Radius



Boom elevation



Electrical system



Hoist



Rotation



Boom extension



Engine



Hookblock



Speed



Boom length



Extension



Hydraulic system



Steering



Boom nose



Frame



Lights



Suspension



Brakes



Fuel tank capacity



Oil



Swing



Cab



Gear



Outrigger controls



Tires



Transmission

Manitowoc Cranes

Regional headquarters

Americas

Manitowoc, Wisconsin, USA

Tel: +1 920 684 6621

Fax: +1 920 683 6277

Shady Grove, Pennsylvania, USA

Tel: +1 717 597 8121

Fax: +1 717 597 4062

Europe, Middle East, Africa

Dardilly, France

Tel: +33 (0)4 72 18 20 20

Fax: +33 (0)4 72 18 20 00

China

Shanghai, China

Tel: +86 21 6457 0066

Fax: +86 21 6457 4955

Greater Asia-Pacific

Singapore

Tel: +65 6264 1188

Fax: +65 6862 4040

Regional offices

Americas

Brazil

Alphaville

Mexico

Monterrey

Chile

Santiago

Europe, Middle East,

Africa

France

Baudemont

Cergy

Decines

Germany

Langenfeld

Italy

Lainate

Netherlands

Breda

Poland

Warsaw

Portugal

Baltar

Russia

Moscow

South Africa

Johannesburg

U.A.E.

Dubai

U.K.

Buckingham

China

Beijing

Chengdu

Guangzhou

Xian

Greater Asia-Pacific

Australia

Brisbane

Melbourne

Sydney

India

Chennai

Delhi

Hyderabad

Pune

Korea

Seoul

Philippines

Makati City

Singapore

Factories

Brazil

Passo Fundo

China

TaiAn

Zhangjiagang

France

Charlieu

Moulins

Germany

Wilhelmshaven

India

Pune

Italy

Niella Tanaro

Portugal

Baltar

Fânzeres

USA

Manitowoc

Port Washington

Shady Grove

This document is non-contractual. Constant improvement and engineering progress make it necessary that we reserve the right to make specification, equipment, and price changes without notice. Illustrations shown may include optional equipment and accessories and may not include all standard equipment.