

Grove YB7725

Product Guide

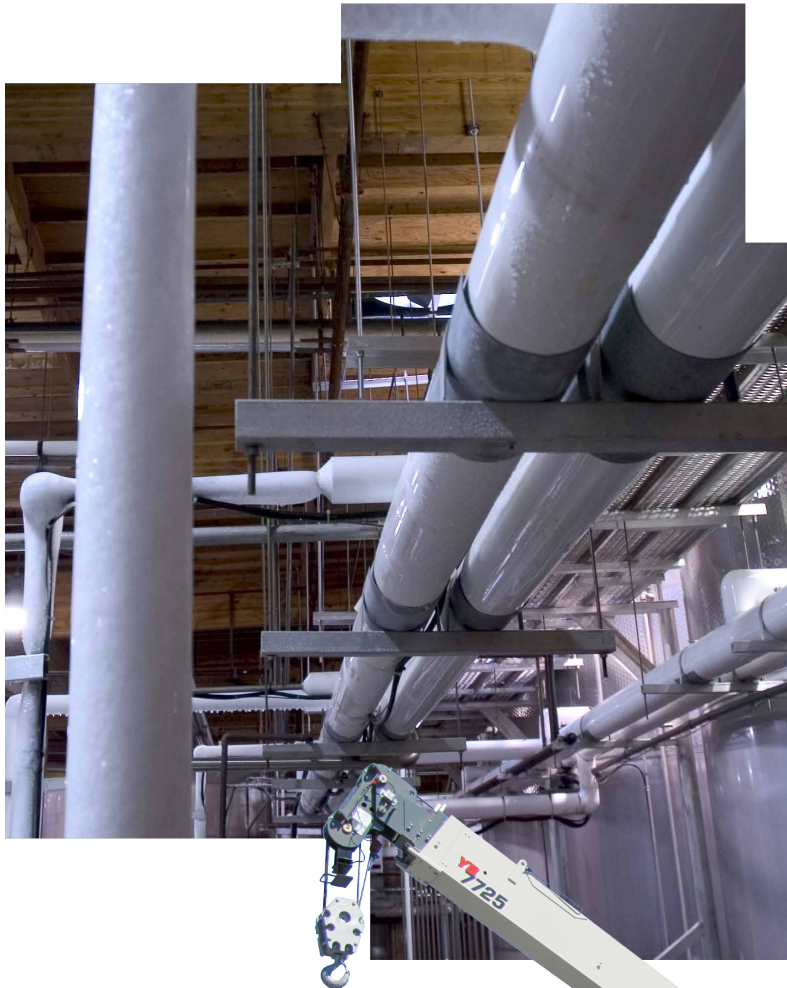

Features

- 22 t (25 USt) capacity
- 21,6 m (71 ft) four-section full power boom
- 13,6 t (15 USt) deck carrying capacity
- Tilt steering wheel
- Load sensing piston hydraulic pump
- Proportional hydraulic controls





The reach and capacity to get the job done

A 5,1 m (17 ft) swingaway extension added to the 21,6 m (71 ft) main boom provides an impressive 28,9 m (95 ft) tip height with a capacity of 2268 kg (5000 lb). A galvanized down-haul ball is included with the extension.

Split door design

The “new” split door design, offered with the optional enclosed cab, allows for the top half to be left open while keeping the bottom half closed for safety.



Specifications

4

Dimensions

7

Range diagram

9

Load chart

10

DIN/ISO range diagram

12

DIN/ISO load chart

13

Symbols glossary

15



Hook block

A galvanized coated hook block is provided as standard to help eliminate rusting of this important crane component.



Operator cab

Hydraulic proportional joystick controls, automotive dash layout, tilt steering wheel, and suspension seat enhances operator comfort and ease of use.

Specifications

Superstructure

Boom

7,21 m – 21,6 m (23 ft 8 in - 71 ft) full power main boom. Four-section boom with three (3) powered sections.

Maximum tip height: 24,0 m (79 ft).

*Offsettable swingaway extension

5,1 m (17 ft) offsettable swingaway extension. Offsets 0°, 15°, and 30° via pivoting boom nose. Stows alongside base boom section.

Maximum tip height: 28,9 m (95 ft).

Boom nose

Two nickel plated steel sheaves mounted on heavy duty tapered roller bearings with removable pin-type rope guards. Quick reeve type boom nose with four-position (0°, +30°, +60°, and +80°) pivoting to minimize head height requirements. Lowers head height by 0,6 m (2 ft).

Boom elevation

Two double acting hydraulic cylinders with integral holding valves provides elevation from -0° to +80°.

Anti-two block device

Standard anti-two block device, which, when activated, provides an audible warning to the operator and “locks-out” all functions whose movement can cause two-blocking.

Load indicator (LSI)

A simple effective and easy to use load indicating system used in conjunction with the anti-two block system to assist the operator in efficient operation of the unit within the limits of the load chart. The display panel displays the hook load and cuts-out the telescope and boom lift down function when a load limit is exceeded. The warning is by a flashing light on the display panel. In conjunction with the load display panel (receiver) there is a wireless transmitter and load sensing pin attached to the boom head that transmits the hook load to the display panel.

(**wireless system**)

*Load Moment Indicator (LMI)

“Graphics Display” of boom angle, boom length, boom radius, capacity, and allows for operator input to set the limit parameters based on the load chart. Displays color coded light bar and audible alarm with function cut-out if load exceeds the load chart parameters.

(**hardwired system**)

Swing

Ball bearing swing circle with 360° continuous rotation. Hydraulic motor driven pinion with brake. Maximum speed: 2.5 rpm

Hydraulic system

One pressure compensated variable displacement axial piston pump with load sensing combined with two (2) gear pumps.

Maximum output of: 238 LPM (79 GPM).

Maximum operating pressure: 248 bars (3600 psi).

Six section valve bank, chassis mounted, operated via dash mounted, pilot pressure hydraulic joysticks. 227 L (60 gal) hydraulic reservoir with sight level gauge and steel side plating to guard against side impacts.

10 micron return line filter with full flow by-pass protection and service indicator.

Hoist specifications

Piston motor driven with automatic spring applied / hydraulically released wet brake.

Maximum hoist pull (first layer): 6804 kg (15,000 lb)

Maximum permissible single line pull:
5670 kg (12,500 lb) (3.5:1 design factor)

Maximum single line speed: 61 m/min (200 fpm)

Rope construction: 6X19 XIPS/IWRC

Rope diameter: 16 mm (5/8 in)

Rope length:
Main hoist: 119 m (390 ft)

Maximum rope stowage:
Main hoist: 151 m (495 ft)

Carrier

Chassis

High strength alloy frame constructed with integral outrigger housings; front and rear lifting, tie-down, and towing lugs. 60 ft² carrydeck size with 13 608 kg (30,000 lb) deck only carrying capacity. Deck coated with anti-skid treatment.

Outriggers

Two-stage hydraulic telescoping beam with vertical jack at the four corners provides extended and down and retracted and down lifting capacities. Integral holding valves on both beam and jack cylinders.

Outrigger pad size:

29,2 cm x 29,2 cm (11.5 in x 11.5 in)

Maximum outrigger pad load:

20 321 kg (44,800 lb) / 339 p.s.i.

Outrigger controls

Independent outrigger control rocker switches for beam or jack selection with separate extend/retract rocker switch. 360° bubble level located inside cab.

Engine (Tier IV)

Cummins QSB 4.5 L, four cylinders, turbo-charged diesel rated at 97 kW (130 hp) at 2500 rpm. Standard 110V engine block heater and cold weather intake grid heater.

Diesel Oxidation/Catalyst, stainless steel, muffler to meet 2012 EPA emissions, combined with a Cummins direct air flow, 2 stage cyclonic air filter system.

Maximum torque: 620 N-m (457 ft lb) at 1500 rpm.

Note: Tier IV engine Required in North American and European Union countries.

Engine (Tier III)

Cummins QSB 4.5L, four cylinders / turbo-charged diesel rated at 97 kW (130 bhp) (Gross) at 2500 rpm. Standard 110V engine block heater and cold weather “ether” assist system. Engine hour meter located inside operators compartment.

Maximum torque: 370 N-m (273 ft lb) at 2500 rpm.

Note: Required for sale outside of North American and European Union countries

Fuel tank capacity

189 L (50 gal)

Grove YB7725

Specifications

Transmission

Powershift with four speeds forward and reverse. Stalk mounted direction shifter with rotary gear selection.

Operators control station

Frame mounted, open air style control station with cab shell includes all crane functions, driving controls, and overhead safety glass. Other standard equipment includes a suspension seat with seat belt, hourmeter, sight level bubble, and 2.5 lb (1.1 kg) fire extinguisher. The dash panel includes a multi-cluster gauge showing fuel, water temperature, oil pressure, and battery voltage. An engine monitoring indicator strip shows engine warning, stop engine, transmission low pressure, transmission high temperature, and low brake system pressure. The load indicator receiver is mounted to the top of the dash panel.

*Operators control station enclosed

Includes the standard cab shell with the addition of front, rear, and right side glass, a split (2 piece) hinged door with sliding glass, front windshield wiper and washer, hot water heater and defroster with fan and cab dome light are included.

Electrical system

Two 12V maintenance-free batteries, 820CCA at 0°. 63 amp alternator.

Drive

2 wheel (rear drive) or 4 wheel selection, front and rear axle drive with planetary hubs and limited slip differential.

Steer

Standard three steering modes. Front two wheel, four-wheel coordinated, and four-wheel crab steer with electronic self alignment, three-position rocker selector on dash panel.

Outside turning radius:

Two-wheel steer: 7,32 m (24 ft)

Four-wheel steer: 4,04 m (13 ft 3 in)

Specifications

Carrier continued

Suspension/axles

Front: Drive/steer with differential and planetary reduction hubs, axle is rigid mounted to frame.

Rear: Drive/steer with differential and planetary reduction hubs, axle is pivot mounted to frame allows up to 3.5° of oscillation.

Oscillation lockouts

Manual switch to engage and disengage the rear axle lockouts. Engage when lifting on rubber and in crab steer mode, Disengage to allow oscillation when traveling over rough terrain.

Brakes

Hydraulic actuated internal wet-disc service brake acting on all four wheels. Dash mounted toggle switch with light for activating or release of the dry disc parking brake mounted on the transmission output yoke.

Tires

Standard: 17.5 x 25 Bias

Optional: 17.5R25 radials

Lights

Full lighting including turn indicators, head, tail, brake and hazard warning lights recessed mounted.

Maximum speed

31,3 km/h (19.5 mph)

Gradeability (theoretical)

63%..... (at engine stall) NO LOAD

38%.....(at engine stall) with 13 608 kg (30,000 lb) DECK LOAD

Gross vehicle weight (G.V.W.)

Open cab: 20 249 kg (44,640 lb)

Enclosed cab: 20 354 kg (44,873 lb)

Miscellaneous standard equipment

22 t (25 USt) Two sheave “galvanize coated” hook block, with “Quick Reeve”.

Back-up motion alarm

Outrigger motion alarm

Dual rear-view mirrors

*Optional equipment

- ▶ **AUXILIARY LIGHTING:** includes cab mounted amber flashing light, dual base boom mounted floodlights
- ▶ **CONVENIENCE PACKAGE:** includes front and rear pintle hitch and headlight/taillight grille covers
- ▶ **ENCLOSED CAB PACKAGE:** includes heater and defroster, cab dome light, all window glass, and two piece split door
- ▶ 5,2 m (17 ft) fixed extension
- ▶ Air conditioner
- ▶ Catalytic convertor
- ▶ Hoist drum rotation indicator
- ▶ Wire rope 3rd wrap indicator with hoist function cut-out
- ▶ 3629 kg (8000 lb) below deck mounted tow winch
- ▶ Foam – filled tires

Dimensions

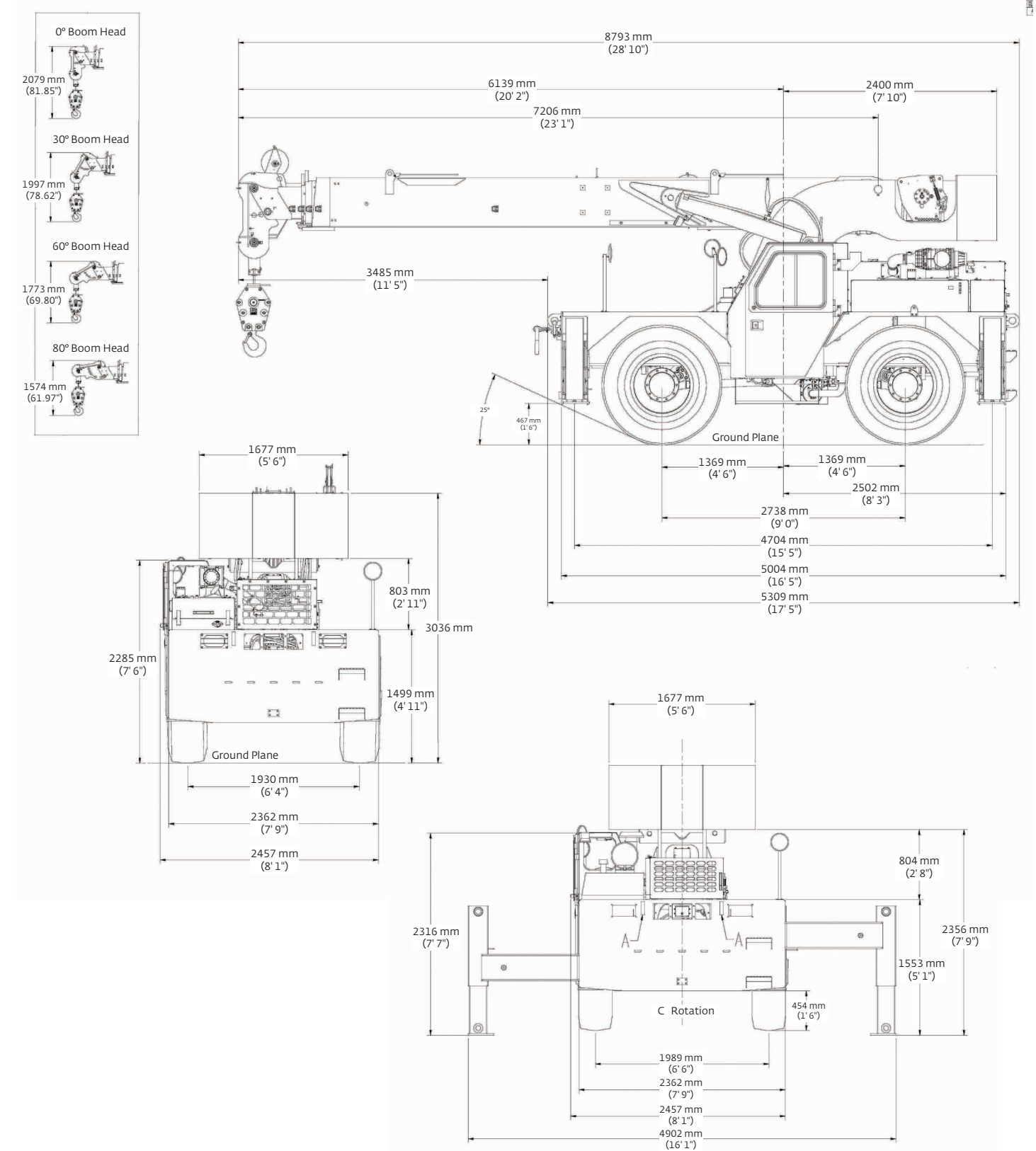

Dimensions

Range diagram

Dimensions										
Tire size	A	B	C	D	E	A	B	C	D	E
17.5 x 25	9784 mm (385.2 in)	8047 mm (316.8 in)	7620 mm (300 in)	7300 mm (287.4 in)	4664 mm (183.6 in)	7102 mm (279.6 in)	4968 mm (195.6 in)	4542 mm (178.8 in)	4084 mm (160.8 in)	1890 mm (74.4 in)
	Two-wheel steer					Four-wheel steer				

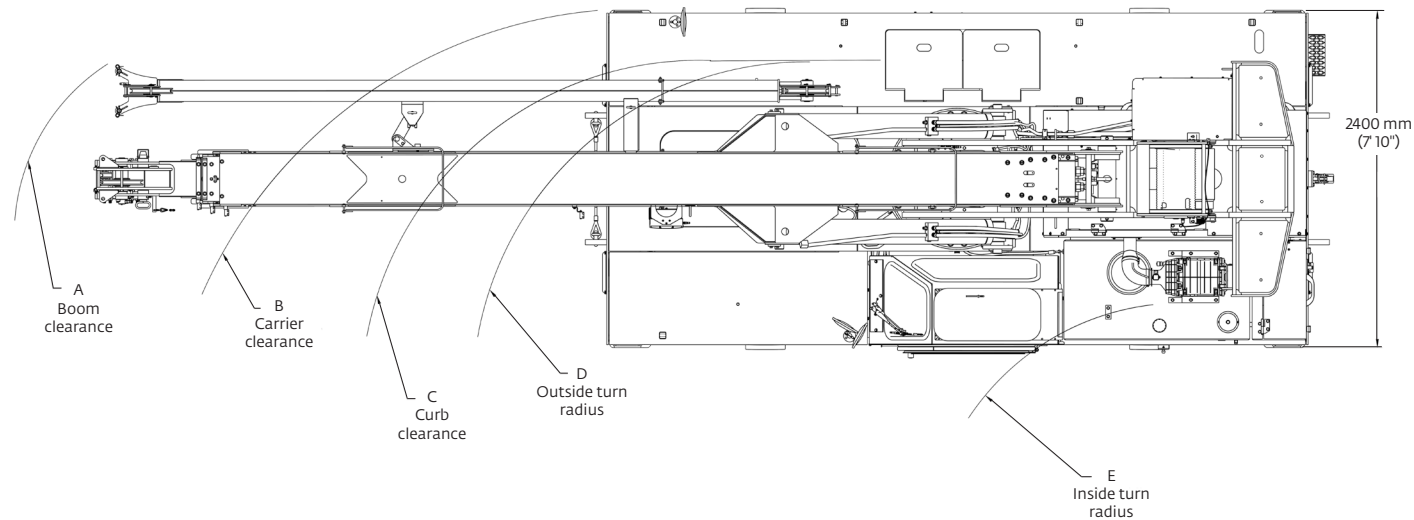

Weights						
	GVW		Front		Rear	
	kg	(lb)	kg	(lb)	kg	(lb)
Basic machine: Including 21,6 m (71 ft) main boom, main hoist with 119 m (390 ft) of wire rope, 22,6 t (25 USt) hookblock, full counterweight, Tier IV engine	20 249	(44,640)	9 904	(21,834)	10 345	(22,806)
Add: 5,1 m (17 ft) fixed swingaway extension and extension carrier brackets and downhaul weight	208	(458)	406	(896)	-199	(-438)
Crane weight	20 456	(45,098)	10 310	(22,730)	10 146	(22,368)
Basic machine: Including 21,6 m (71 ft) main boom, main hoist with 119 m (390 ft) of wire rope, 22,6 t (25 USt) hookblock, full counterweight, Tier IV engine	20 249	(44,640)	9 904	(21,834)	10 345	(22,806)
Add: Enclosed cab with heater and defroster	106	(233)	104	(104)	129	(129)
Crane weight	20 354	(44,873)	9 951	(21,938)	10 403	(22,935)

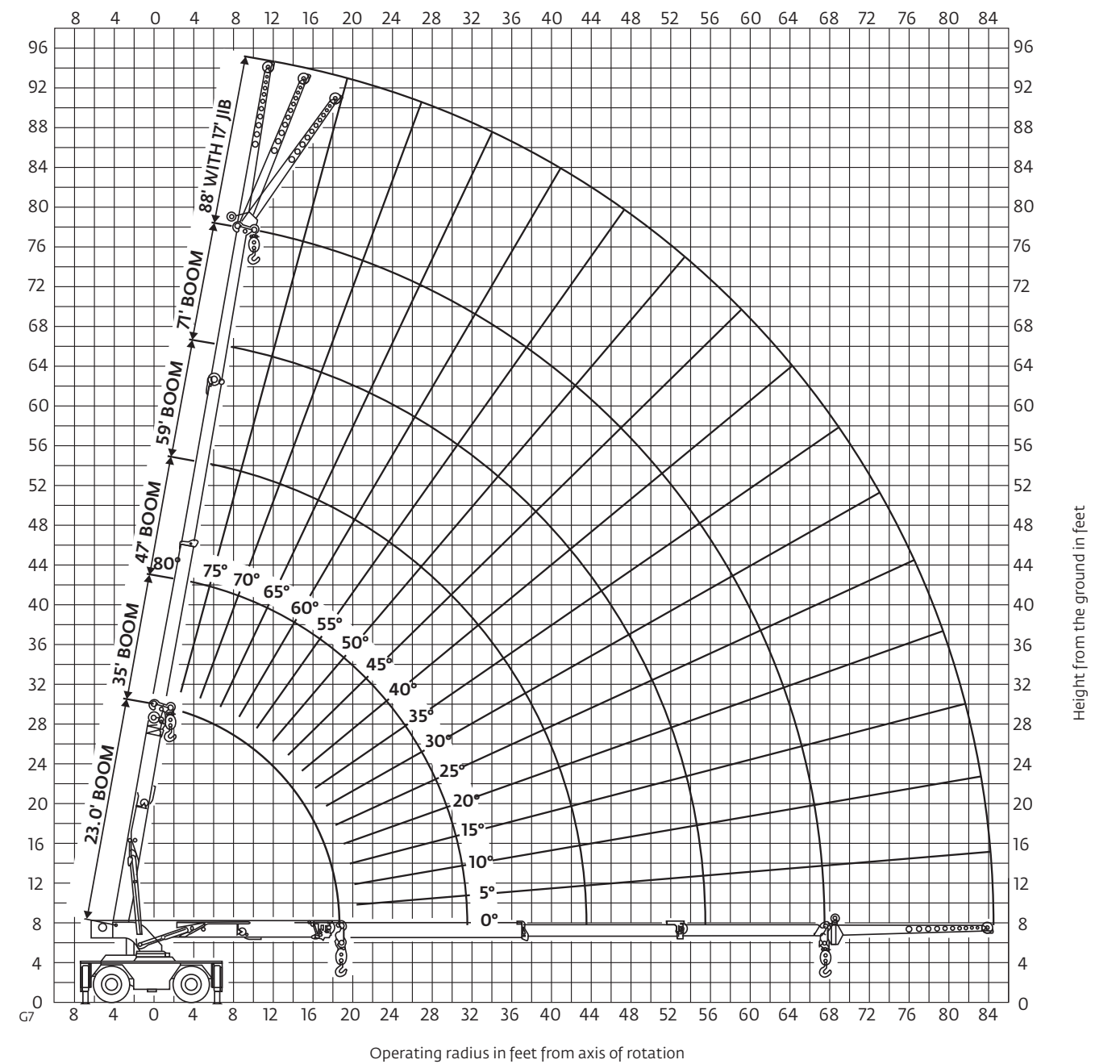

5,2 m JIB CAPACITY ON EXTENDED OUTRIGGERS (kg)					
Main Boom Angle (deg)	Jib Offset Angle				30° Any Boom Length
	0°		15°		
	To 18,0 m Main Boom	To 21,5 m Main Boom	To 18,0 m Main Boom	To 21,5 m Main Boom	
80	—	—	2270	2270	1590
75	3400	—	2000	2000	1410
70	2770	—	1770	1770	1270
65	2270	2090	1590	1590	1160
60	1950	1720	1430	1430	1070
55	1720	1500	1290	1290	1000
50	1540	1320	1180	1180	0950
45	1380	1180	1090	1090	0910
40	1270	1090	1020	1020	0880
35	1180	0980	0980	0930	0860
30	1090	0880	0940	0840	0830
25	1040	0790	0930	0780	—
20	1000	0730	0910	0720	—
15	0950	0680	0880	0690	—
10	0930	0660	—	—	—
5	0920	0660	—	—	—
0	0910	0650	—	—	—

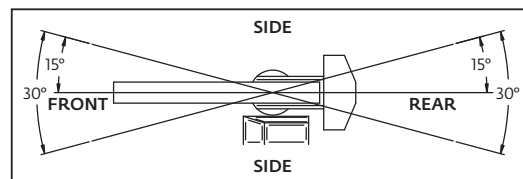

1) The rated loads are the maximum lift capacities as determined by operating radius, boom length and boom angle. The operating radius is the horizontal distance from a projection of the axis of rotation to the supporting surface, before loading, to the center of vertical hoist line or tackle with load applied.

2) Rated load columns for discrete boom lengths apply when actual boom length is within +/- 0,3 m of discrete length. When boom length or radius or both are between points listed on capacity chart, the smallest load shown at either the next larger radius or boom length shall be used.

3) For operating radius not shown, use load rating of next larger radius.

4) The rated loads shown on outriggers do not exceed 85% of actual tipping. The rated loads shown on rubber do not exceed 75% of actual tipping. These ratings are based on freely suspended loads with the crane leveled, standing on a firm, uniform supporting surface. Practical working loads depend on supporting surface, operating radius and other factors affecting stability. Hazardous surroundings, climatic conditions, experience of personnel and proper training must all be taken into account by the operator.

5) The weights of all load handling devices such as hooks, hook blocks, slings, etc., except the hoist rope, shall be considered part of the load. See reduction chart.

6) Ratings on outriggers are for either outriggers fully extended and down or fully retracted and down. Ratings for outriggers fully retracted and down will apply for any intermediate outrigger setting.

7) Ratings on rubber depend on tire capacity, condition of tires and proper inflation pressure (7.6 bar). When replacing tires, contact Manitowoc for proper specifications. Loads on rubber may be transported at a maximum speed of 4,0 km/h on a smooth, hard, level surface with boom retracted to the shortest length possible and centered over front. For 360° ratings on rubber, rear axle oscillation locks must be in place. Do not use jib with crane on rubber.

8) The maximum combined total boom and deck load is 9070 kg. The maximum deck load only is 13 610 kg.

9) Do not induce any external side loads to boom or jib.

80024905YB

TRANSPORTATION AND LIFTING DATA - YB7725

- LIFTING OF ENTIRE CRANE OR MAJOR CRANE ASSEMBLIES MUST BE ACCOMPLISHED BY UTILIZING SPECIFIC FITTINGS INDICATED ON ADJACENT CHART. USE OF FITTINGS FOR PURPOSES OTHER THAN THOSE DESIGNATED ON CHART IS PROHIBITED. FITTING CAPACITIES ARE MAXIMUM ALLOWABLE LOADS PER INDIVIDUAL FITTING.
- RIGGING PERSONNEL SHALL BE RESPONSIBLE FOR PROPER SELECTION AND PLACEMENT OF ALL SLINGS AND LOAD HANDLING DEVICES.
- DIMENSIONS AND WEIGHTS SHOWN ARE ESTIMATED FOR LARGEST CONFIGURATION AVAILABLE. WEIGHTS DO NOT INCLUDE BOOM EXTENSION AND OR JIB, UNLESS OTHERWISE INDICATED.
- RIGGING PERSONNEL SHALL VERIFY DIMENSIONS AS REQUIRED FOR CLEARANCE.
- DO NOT USE COUNTERWEIGHT LIFT LOCATIONS OR BOOM SLING POINT FOR LIFTING OR TIE DOWN OF ENTIRE CRANE.
- LIFTING OF THE COUNTERWEIGHT TO BE ACCOMPLISHED WITH A PROPERLY RATED 1/2 INCH EYEBOLT.

FITTING	NO. / UNIT	LIFT	TOW	TIE DOWN	BOOM LIFT	CWT LIFT	CAPACITY-TONNES [TONS]				
							LIFT	TOW	TIE DOWN		
									FORE & AFT	SIDE	DOWN
A	4	X	X	X			9.1 [10]	27.2 [30]	27.2 [30]	0.9 [1]	27.2 [30]
B	4				X		1.8 [2]				
C	1					X	0.9 [1]				
D	1					X	0.9 [1]				

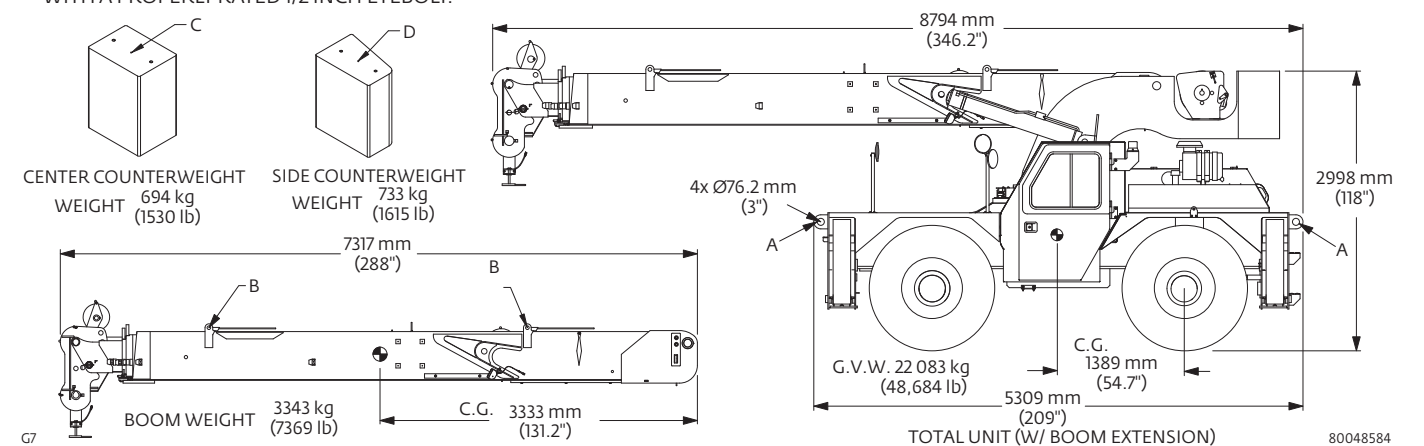

LOAD DISTRIBUTION CHART





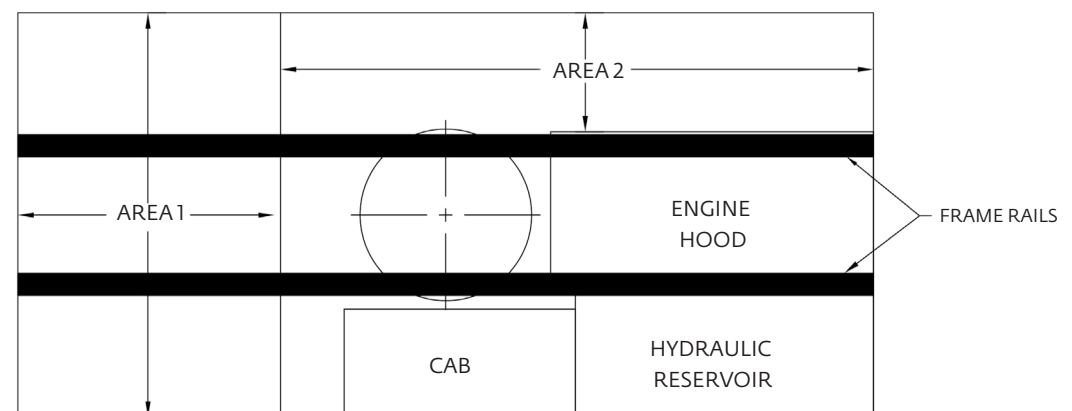



























AREA 1	
5,21 m sq (56.1 sq ft)	8981 kg (19,800 lb)
AREA 2	
2,41 m sq (25.9 sq ft)	4627 kg (10,200 lb)

- Maximum travel speed with any or all loads - 4,0 km/h (2.5 mph)
- Loads to be transported on smooth level surfaces only.
- Boom must be retracted and in center forward position.
- Any combination or total of areas 1 and 2 may be used.
- Lifting is not permitted when carry deck is loaded except for loading and unloading carry deck.
- Rated pick and carry loads may be transported on deck area 1 provided the load is cribbed directly on the frame rails.



Symbols glossary

Notes

 Axles	 Counterweight	 Grade	 Outriggers
 Boom	 Drive	 Heavy duty jib	 Radius
 Boom elevation	 Electrical system	 Hoist	 Rotation
 Boom extension	 Engine	 Hookblock	 Speed
 Boom length	 Extension	 Hydraulic system	 Steering
 Boom nose	 Frame	 Lights	 Suspension
 Brakes	 Fuel tank capacity	 Oil	 Swing
 Cab	 Gear	 Outrigger controls	 Tires
			 Transmission

Manitowoc Cranes

Regional headquarters

Americas

Manitowoc, Wisconsin, USA

Tel: +1 920 684 6621

Fax: +1 920 683 6277

Shady Grove, Pennsylvania, USA

Tel: +1 717 597 8121

Fax: +1 717 597 4062

Europe, Middle East, Africa

Ecully, France

Tel: +33 (0)4 72 18 20 20

Fax: +33 (0)4 72 18 20 00

China

Shanghai, China

Tel: +86 21 6457 0066

Fax: +86 21 6457 4955

Greater Asia-Pacific

Singapore

Tel: +65 6264 1188

Fax: +65 6862 4040

Regional offices

Americas

Brazil

Alphaville

Mexico

Monterrey

Chile

Santiago

Europe, Middle East, Africa

Czech Republic

Netvorice

France

Baudemont

Cergy

Decines

Germany

Langenfeld

Hungary

Budapest

Italy

Lainate

Netherlands

Breda

Poland

Warsaw

Portugal

Baltar

Russia

Moscow

South Africa

Johannesburg

U.A.E.

Dubai

U.K.

Buckingham

China

Beijing

Chengdu

Guangzhou

Xian

Greater Asia-Pacific

Australia

Brisbane

Melbourne

Sydney

India

Chennai

Delhi

Hyderabad

Pune

Korea

Seoul

Philippines

Makati City

Singapore

Factories

Brazil

Passo Fundo

China

TaiAn

Zhangjiagang

France

Charlieu

Moulins

Germany

Wilhelmshaven

India

Pune

Italy

Niella Tanaro

Portugal

Baltar

Fânzeres

Slovakia

Saris

USA

Manitowoc

Port Washington

Shady Grove

This document is non-contractual. Constant improvement and engineering progress make it necessary that we reserve the right to make specification, equipment, and price changes without notice. Illustrations shown may include optional equipment and accessories and may not include all standard equipment.